



**Scott Schroeder**  
September 10, 2012

## **Preparing for a Full-Course Meal**

**Honeywell**

## Appetizers

### Amuse-Bouche



1%  
to  
5%



### Antipasto



### Heavy Hors D'oeuvre

5-7 Year Payback



## Dessert



**20+ Year  
Payback**



## Main Course



17%  
to  
22%

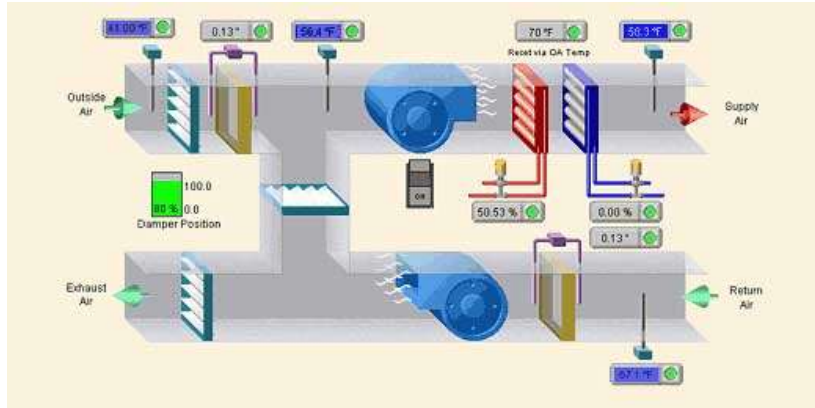

18+ Year Payback

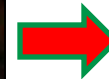



Constant Volume  
to VAV  
20-year payback

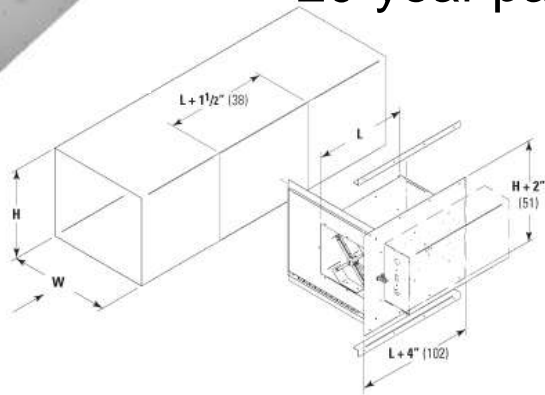

Lighting Upgrades  
15-year payback



**\$620,218**  
**Annual Energy**  
**Savings**

*16-year payback*

**Baseline**  
**Reduction**  
**of 42%**

Building Envelope  
11-year payback

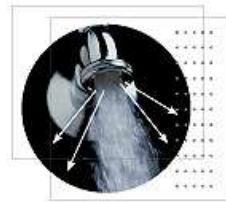

Variable Flow Technology  
Works with existing infrastructure  
with no compromise to performance



Plumbing  
Improvements  
7-year payback



Controls Retro-commissioning  
7-year payback

## A Full Day's Serving

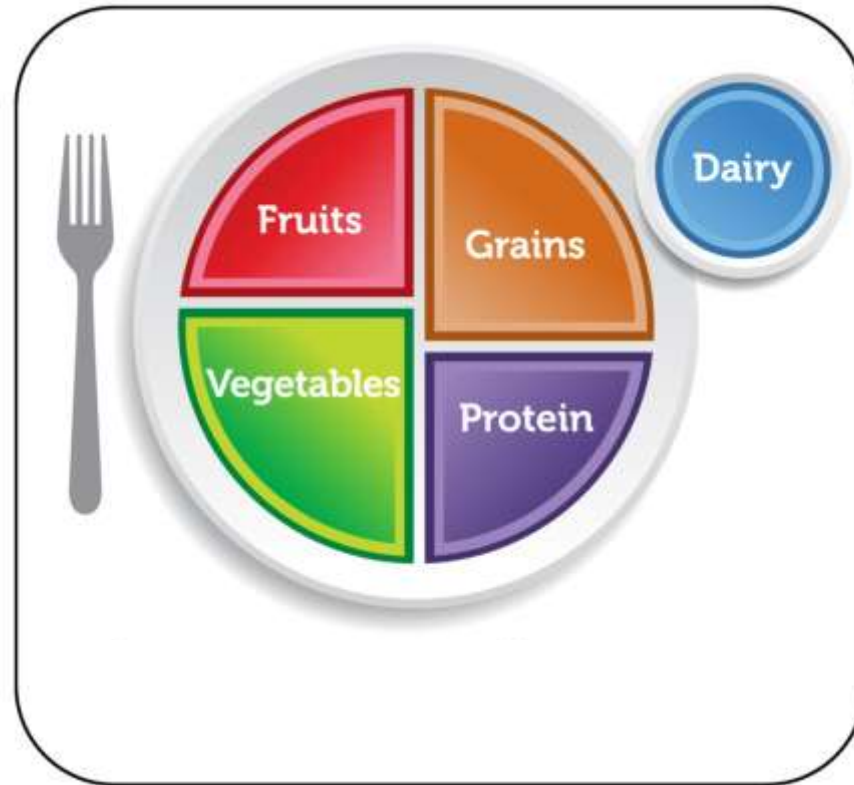

*Your Bottom Line Will Thank You*